

Improved control of yeast pitching rate using the Aber™ Yeast Monitor – financial implications

John Carvell, Aber Instruments Ltd., UK

1 Introduction

In order to produce consistent fermentation performance and controlled beer quality, it is essential that yeast stocks are managed in such a way that variability in physiological condition is minimal.

Providing that this is accomplished and there is adequate control of other important variables such as wort composition and oxygen concentration, fermentation performance is governed, in a large part by the yeast pitching rate. It follows that procedures that lead to precise and repeatable control of yeast pitching rate will result in consistent fermentation performance.

Here an attempt is made to quantify, in financial terms, the advantages of using an Aber™ Yeast Monitor for the control of yeast pitching rate. Financial calculations are based on a brewery producing approximately 1.6 million hl of a single quality of keg lager beer (4.0% abv) from a 15° Plato high gravity wort.

2 The Aber™ Yeast Monitor

The Aber™ Yeast Monitor is an on-line probe that measures live yeast concentration, overcomes many of the problems associated with traditional manual methods of yeast concentration measurement. It is based on measuring capacitance at a fixed radio-frequency *ie* the measured capacitance due to intact yeast cells is directly proportional to the amount of viable yeast within the sample

The most recent Yeast Monitor instrument, the Model 720 introduced at the end of 2005 by Aber Instruments Ltd (UK), is shown in Figure 1.



Figure 1 Yeast Monitor Model 720 (Aber Instruments Ltd, UK)

3 Product consistency

Providing control of wort oxygen concentration and wort composition is adequate (which it should be in the majority of breweries) poor control of pitching rate is the single major contributor to variability in beer quality.

Clearly, variable beer quality may have negative effects in terms of consumer choice and therefore this may be a major factor in determining brand profitability. The financial consequences of variable beer quality are difficult, if not impossible, to quantify but can be calculated that a 0.1% decrease in sales represents a loss of £16,216 in margin for a 1 million hl brewery.

4 Manpower costs

Use of the Aber™ Yeast Monitor for yeast management will impact on manpower costs since there will be a reduced need for skilled laboratory staff capable of carrying out yeast analyses. In a large brewery it would be likely that savings equivalent to one person would be feasible, particularly if the Yeast Monitor is multiplexed and also used to control yeast cropping (eliminating the need for visual monitoring of yeast interfaces). An example of using the Yeast Monitor for both pitching and cropping control is shown in Figure 2.

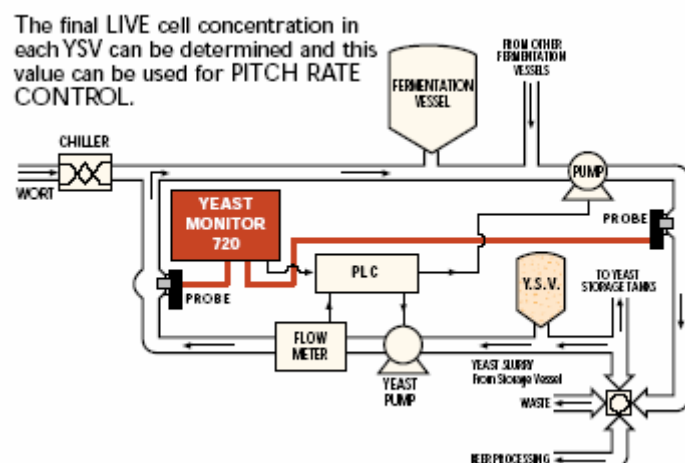

Figure 2 Yeast Monitor 720 being used for automatic pitching and cropping control

The magnitude of the potential savings are difficult to quantify, nevertheless assuming manpower costs of 4.4 Euros per hl it follows that in a one million hl brewery every 1% reduction in manpower costs would attract savings of 44,000 Euros per annum.

5 Fermentation efficiency

Fermentation efficiency, as measured in terms of ethanol yield, is defined by three inter-related factors.

- initial wort concentration (or OG)
- the specific gravity of the resultant beer and
- the ethanol concentration of the beer

Good control of fermentation is essential in order to ensure that the desired relation is maintained between the initial concentration of sugar in the wort and the final ethanol concentration in the beer. Failure to control the extent of yeast growth during fermentation will change the relation between the quantity of extract used for new biomass formation and that which is converted into ethanol.

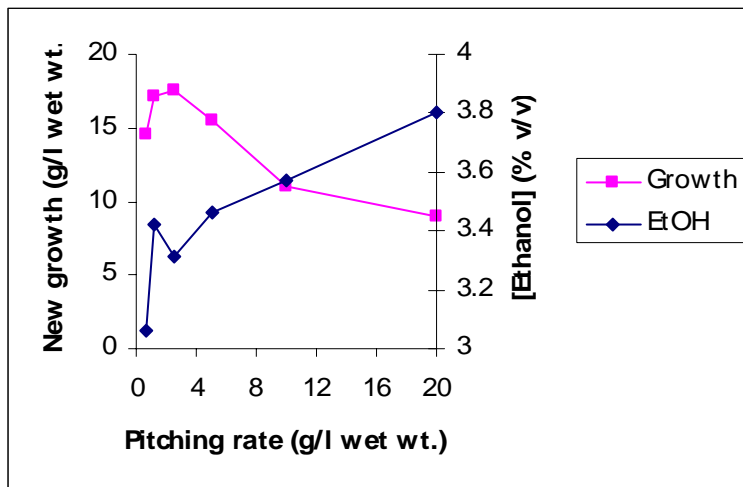

Figure 3. Effect of varying pitching rate on yeast growth and ethanol yield during fermentation of an oxygen saturated all-malt 15°P lager wort.

Nevertheless, there was a correlation between yeast growth and ethanol yield (Figure 3).

As indicated, ethanol yield was relatively low at the lower yeast pitching rates. This was a consequence of the failure of the wort to become fully attenuated. At medium to higher pitching rates, there was an inverse correlation between the extent of yeast growth and ethanol formation. Within the range of pitching rates used for this type of fermentation (2.5 - 3.0 g/l wet wt. yeast) it can be seen that errors in pitching rate control would potentially result in variable yields of ethanol and hence, variable fermentation efficiency.

The financial implications of excessive yeast growth can be illustrated by the following example. In a high gravity fermentation using 1600hl of an all-malt wort with an initial concentration of 15°P the expected yield of ethanol would be *ca.* 6.7% v/v. If the yield of ethanol was reduced by 0.1% v/v as a result of poor control of pitching rate the overall yield of beer, after dilution to 4.1% would be reduced by:

$$\frac{1600 \times 6.7}{4.1} - \frac{1600 \times 6.6}{4.1} = 39\text{hl}$$

In order to generate 1 million hl of beer at high gravity it would be necessary to perform 625 x 1600hl fermentations. If this loss rate was applied to half this number of fermentations the lost volume of diluted beer would amount to (39 x 312) = 12,168hl of beer. There would be no decrease in the usage of raw materials and the operating costs of managing fermentations would be unchanged. **Assuming a production cost for the beer of 13 Euros per hl, the financial penalty of fermentation inefficiency would be equivalent to 158,184 Euros.**

6 Financial considerations for new breweries or increased fermentation capacity

Poor pitching rate control has the potential to produce variable fermentation cycle times. One of the consequences of this is that it is not possible to produce an accurate forward plan. The financial consequences of this are usually expressed in terms of capital avoidance. Since it is not possible to forecast with any accuracy when fermentations will end it is necessary to have a certain number of

surplus vessels in order to ensure that empty and clean fermenters will always be available for use when required.

Experience suggests that with a poorly controlled fermentation process cycle times would be likely to vary between +/- 3 days of the target. A large element of this inconsistency can be attributed to variability in pitching rate control where traditional methods of control are used (with the caveat that other sources of inconsistency would also be contributory factors).

The capital cost of a typical modern cylindroconical fermenter is approximately 700,000 Euros. If a new brewery is being constructed or additional fermenters are being installed in an existing plant to extend fermentation capacity the opportunity to reduce the total vessel count would attract significant cost savings.

7 Conclusions

- With the advent of global brands, produced using very large batch sizes, precise control of fermentation is of fundamental importance for maintaining high process efficiency and high quality consistent product.
- Of all fermentation variables yeast pitching rate and initial wort dissolved oxygen concentration have pivotal roles in determining the outcome of the process
- It has been demonstrated here that failure to exert precise control over these variables has the potential to inflict severe financial penalties on the operation of the brewery.
- The Aber™ Yeast Monitor provides a cost effective route for the automatic control of yeast pitching rate. Precision and repeatability of such control systems are superior to those based on more traditional methods for quantifying viable yeast concentration.